

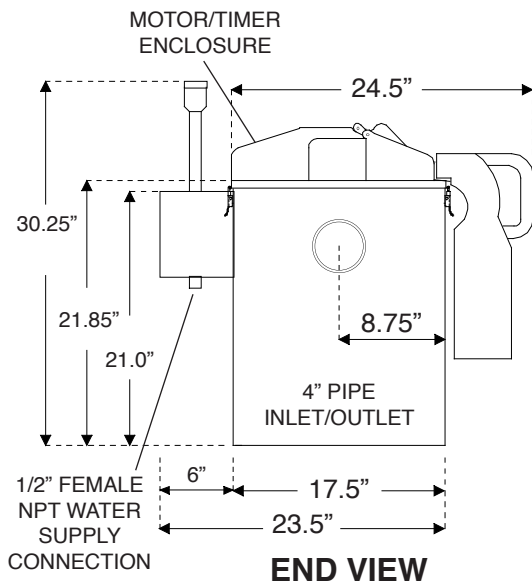

Big Dipper® AST Central Automatic Grease Removal Systems

W-750-AST Specifications



END VIEW

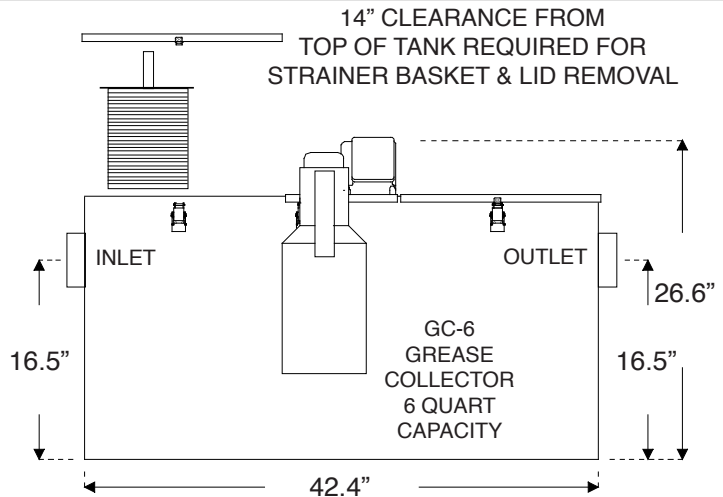

SIDE VIEW

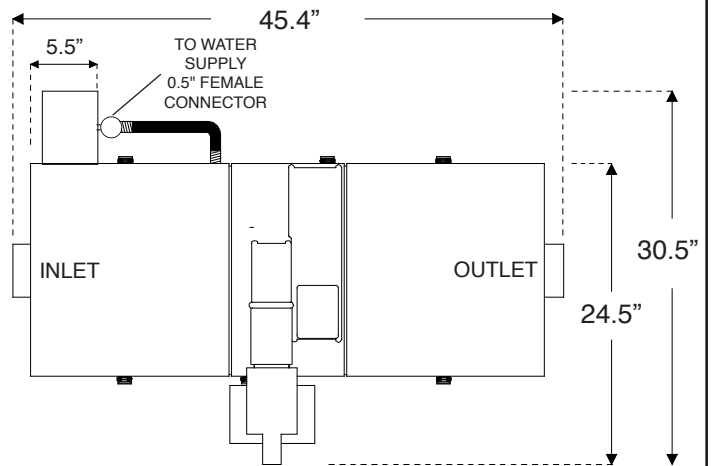

TOP VIEW

FEATURES:

- Fully automatic self cleaning cycle. Removes collected grease, oils and solids from unit without any operator assistance. Comes complete with 24-hour timer.
- Constructed of corrosion resistant materials suitable for installation in virtually any location. Attractive sanitary Stainless Steel exterior.
- Integrated Motor/Grease Outlet/Heater/Lid enables a fast, do-it-yourself unit operation reversal.
- Easy lift grease collector simplifies grease collection container emptying.
- Compact footprint.

TECHNICAL DATA

Materials:	Exterior: 304 Stainless Steel, Bright Finish
	Interior: Rotationally Molded Polyethylene
Electrical:	115 VAC, 60 Hz, 535 Watts (4.6 Amps)
Maximum Inlet Flow Rate:	75 GPM
Number of Skimming Wheels:	1
Skimming Rate:	20 Pounds Per Hour
Grease Retention Capacity:	150+ Pounds
Eductor Pump Operation Requirements:	50 PSI min., 12 GPM





Big Dipper® AST Central Automatic Grease Removal Systems

W-750-AST Specifications

INSTALLATION INFORMATION

DO...

Allow a minimum of 14" clearance from top of tank for removal of unit lid.

READ instruction manual included with system before doing anything.

Install unit allowing for the minimum clearances shown.

Provide a min. 50 PSI, 12 GPM Water Supply for solids pump operation

Make sure the height above the Internal Strainer Access Cover is enough to remove the strainer.

Make piping connections with rubber "No Hub" connectors.

Keep outlet piping as straight as possible. Use only "sweep" connections.

Install vent on outlet piping.

Fill the tank with water before energizing the power to the motor and heater.

Set Programmable Time Controller for proper operating times.

Suggested Minimum Footprint Dimensions

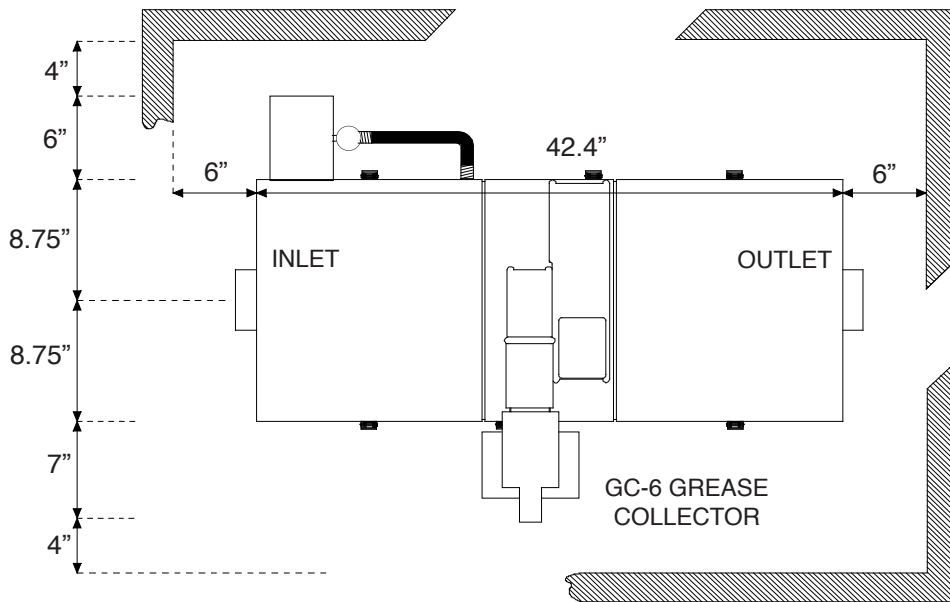

DON'T . . . Install "P" trap on outlet connection of tank. (Note: the unit already has an internal gas trap). Reduce pipe size on outlet piping.

Note: Installations must comply with all applicable local, state, and national codes for your area.

Job Specification:

Grease and oils separator(s) shall be Thermaco **Big Dipper** automatic grease/oil recovery system(s) as manufactured by Thermaco, Inc., Asheboro, North Carolina as noted on plans.

Separator Specifications:

Furnish and install ____ Thermaco **Big Dipper** Model No. W-750-AST, bright finish type 304 stainless steel exterior, rotationally molded polyethylene interior automatic self-cleaning grease and oil recovery separator(s) for floor mounted or partially recessed installation, rated at 75 gallons per minute peak flow, 150 pounds of grease capacity and including as an integral part of the unit, 1 rotating gear hydrophobic wheel assembly for automatic grease/oil removal, an integral flow control device, self-regulating enclosed electric immersion heater, a vessel vent, an integral gas trap, an integral programmable 24-hour multi-event time control, a field reversible motor location, a field reversible grease/oil sump outlet, quick release stainless steel lid clamps, a gasketed and fully removable 304 stainless steel lid, lift-out filter basket access, an eductor transfer pump controlled by repeat cycle timer, and a separate grease and oils collection container. Eductor pump shall be supplied with a 0.5" female connector for attachment to facility-supplied water supply. Eductor pump shall be supplied with an approved vacuum breaker. Electric assembly shall be tested to comply with pertinent sections of the Standards for Safety ANSI/UL 73 and/or ANSI/UL 1004. Electric motor shall be equipped with thermal overload protection with automatically resettable switch.



Big Dipper® AST Central Automatic Grease Removal Systems

W-1250-AST Specifications

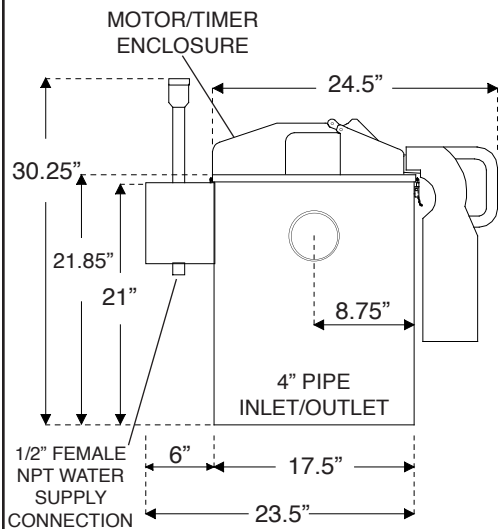

END VIEW

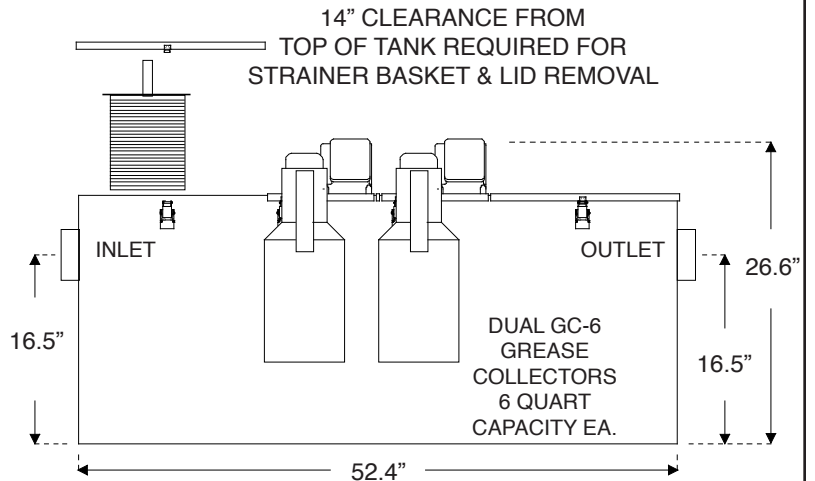

SIDE VIEW

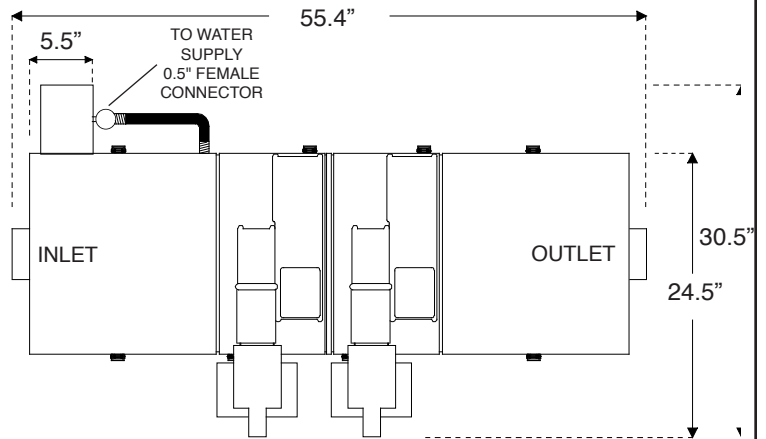

TOP VIEW

FEATURES:

- Fully automatic self cleaning cycle. Removes collected grease, oils & solids from tank without any operator assistance. Comes complete with two 24-hour timers.
- Constructed of corrosion resistant materials suitable for installation in virtually any location. Attractive sanitary Stainless Steel exterior.
- Integrated Motor/Grease Outlet/Heater/Lids enables fast, do-it-yourself unit operation reversal.
- Easy lift grease collectors simplify grease collection container emptying.
- Compact footprint.

TECHNICAL DATA

Materials:	Exterior: 304 Stainless Steel, Bright Finish
	Interior: Rotationally Moulded Polyethylene
Electrical:	115 VAC, 60 Hz, 1055 Watts (9.1 Amps)
Maximum Inlet Flow Rate:	125 GPM
Number of Skimming Wheels:	2
Skimming Rate:	40 Pounds Per Hour
Grease Retention Capacity:	300+ Pounds
Eductor Pump Operation Water Requirements:	50 PSI min., 12 GPM





Big Dipper® AST Central Automatic Grease Removal Systems

W-1250-AST Specifications

INSTALLATION INFORMATION

DO...

Allow a minimum of 14" clearance from top of tank for removal of unit lid.

READ instruction manual included with system before doing anything.

Install unit allowing for the minimum clearances shown.

Provide a min. 50 PSI, 12 GPM Water Supply for solids pump operation

Make sure the height above the Internal Strainer Access Cover is enough to remove the strainer.

Make piping connections with rubber "No Hub" connectors.

Keep outlet piping as straight as possible. Use only "sweep" connections.

Install vent on outlet piping.

Fill the tank with water before energizing the power to the motor and heater.

Set Programmable Time Controller for proper operating times.

Suggested Minimum Footprint Dimensions

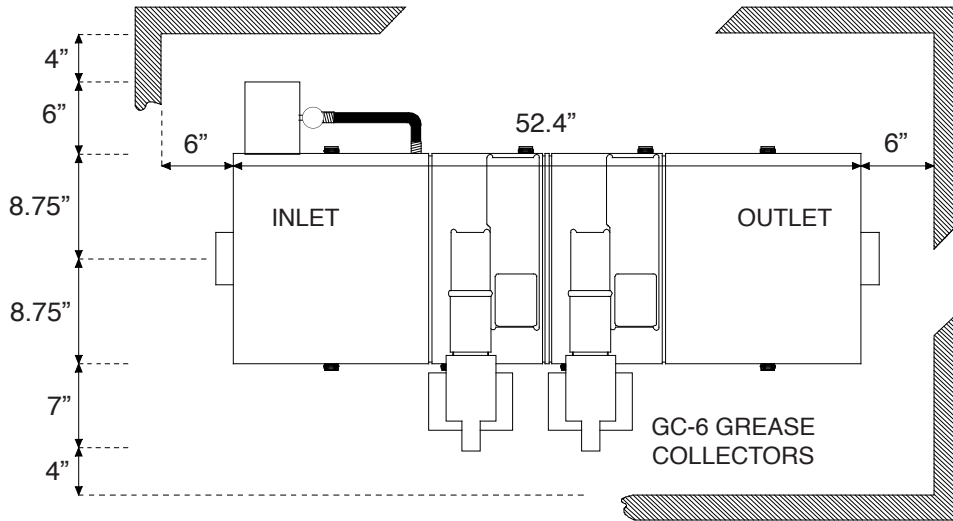

DON'T . . . Install "P" trap on outlet connection of tank. (Note: the unit already has an internal gas trap). Reduce pipe size on outlet piping.

Note: Installations must comply with all applicable local, state, and national codes for your area.

Job Specification:

Grease and oils separator(s) shall be Thermaco **Big Dipper** automatic grease/oil recovery system(s) as manufactured by Thermaco, Inc., Asheboro, North Carolina as noted on plans.

Separator Specifications:

Furnish and install ___ Thermaco **Big Dipper** Model No. W-1250-AST, bright finish type 304 stainless steel exterior, rotationally molded polyethylene interior automatic self-cleaning grease and oil recovery separator(s) for floor mounted or partially recessed installation, rated at 125 gallons per minute peak flow, 300 pounds of grease capacity and including as an integral part of the unit, two rotating gear hydrophobic wheel assemblies for automatic grease/oil removal, an integral flow control device, two self-regulating enclosed electric immersion heaters, a vessel vent, an integral gas trap, two integral programmable 24-hour multi-event time controls, field reversible motor locations, field reversible grease/oil sump outlets, quick release stainless steel lid clamps, a gasketed and fully removable 304 stainless steel lid, lift-out filter basket access, an eductor transfer pump controlled by repeat cycle timer, and two separate grease and oils collection containers. Eductor pump shall be supplied with a 0.5" female connector for attachment to facility-supplied water supply. Eductor pump shall be supplied with an approved vacuum breaker. Electric assembly shall be tested to comply with pertinent sections of the Standards for Safety ANSI/UL 73 and/or ANSI/UL 1004. Each electric motor shall be equipped with thermal overload protection with automatically resettable switch.

©2005 Thermaco, Inc. • All rights reserved • Patented/Patents Pending • Specifications subject to change without notice